



Carestation 750 Anesthesia Delivery System

Individualized
therapy at your
fingertips



Individualized therapy at your fingertips

In today's complex perioperative settings, patients are now having procedures at older and younger ages, and their conditions are more diverse and challenging than ever.

GE empowers you with cutting-edge technology to deliver better care with ease, efficiency and precision.

The Carestation™ 750 Anesthesia Delivery System is a modern, sophisticated and easy-to-navigate anesthesia workstation. It's built on our clinically proven platform to give you the control and accuracy you need for high-quality, attentive care.



- A Advanced clinical tools that help you deliver individualized therapy.
- B An intuitive user interface and intelligent features for visual guidance during a case.
- C Efficient, ergonomic design for seamless workflow and ease of service.

These comprehensive capabilities help you deliver precise and reliable anesthesia care to patients regardless of age, size, background and acuity.



A ADVANCED CLINICAL TOOLS

Embrace simplicity in personalized care

*No two cases and no
two patients are the same.*

GE Healthcare is committed to providing accurate clinical monitoring of all components, so clinicians can deliver the optimum, tailor-made general anesthesia to each patient.

The Carestation 750 system features



CUSTOMIZABLE CASE PROFILES

You can create case profiles according to patient characteristics (such as pediatric, adult, obese), type of procedure, or physician preference. Each profile—available with one touch—includes preset alarm limits, apnea time, ventilation parameters, gas mix, and other essential parameters.*

*Clinicians review and adjust parameters of each case profile prior to starting each case.



YOUR CHALLENGE

Spending an extra
15–30% on
anesthetic agents due
to high fresh gas flow rates¹

Contributing extra
greenhouse gases equivalent
up to **350 cars/year**^{2,3}

Improper ventilation
during anesthesia can
cost over **\$25K/case**
in post-op lung
complications⁴

40%
of patients
arrive to the PACU
with residual block
each year⁵

OUR SOLUTION

Low-flow software

ecoFLOW software helps support clinicians in the practice of low-flow anesthesia by predicting how much O₂ is needed within the fresh gas flow for each patient to minimize the risk of delivering a hypoxic mixture to the patient—even at very low flows. ecoFLOW has the potential to deliver a positive impact on the environment and reduce agent costs when agent waste gases are reduced.

Lungprotective ventilation (LPV) software

Programable, step-by-step lung recruitment maneuver software on the main ventilation display that includes real-time compliance measurement to assess the procedure effectiveness. An exit PEEP feature lets you keep the lung open after the procedure is complete.

Integrated monitoring for tailored anesthesia

The Adequacy of Anesthesia⁹ concept (AoA) in the GE integrated CARESCAPE™ Monitor utilizes parameters to assess patient responses to anesthetics, opioids and neuromuscular blocking agents during surgery. This may help clinicians reduce drug utilization and optimize patient throughput.

B INTUITIVE USER INTERFACE

Tools at your fingertips with an intuitive interface

The user interface for the Carestation 750 system helps you deliver quality care with natural ease. It allows you to breeze through cases, so you can worry less about the machine and devote more attention to your patients.

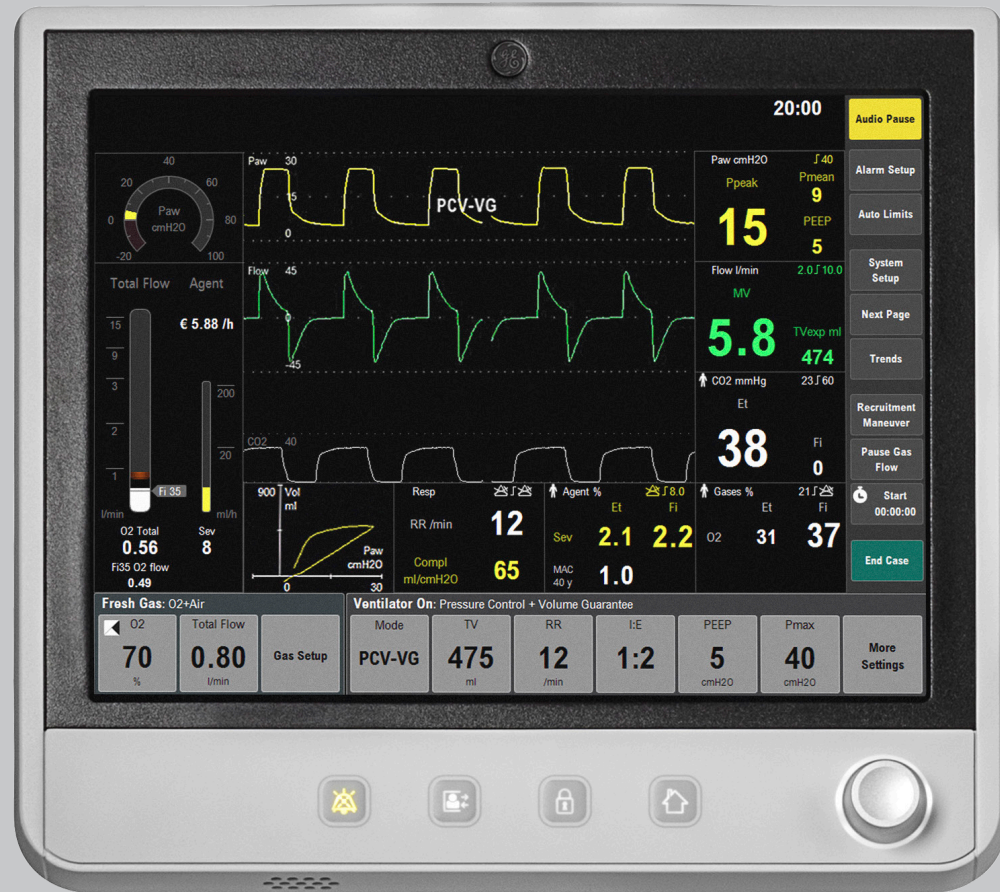

1

DIRECT ACCESS TO MAIN PROCEDURES

There's no more clicking through menus and submenus to access functions you use most often. Lung Recruitment, Timer, Pause Gas Flow, Auto Alarm, Turn Manual Alarm Off and other settings appear on the main ventilation display —right at your fingertips.



2

2

CLEAR STATUS INDICATION

You get clear indication of system status on the display when using Auxiliary Common Gas Outlet (ACGO), Aux O₂ or standby mode, or when you switch from bag to mechanical ventilation.

4

4

CONSISTENT USER INTERFACE

A standard user interface on the Carestation anesthesia machine and the CARESCAPE patient monitor helps reduce training time, so you can easily follow your patients from transport to bedside.

Pause Gas Flow

1

3

INTELLIGENT LIGHTING

Whenever auxiliary ports are in use, lighting indicates the active flow controls. Visual reinforcement on the ventilation screen highlights flow status.

3

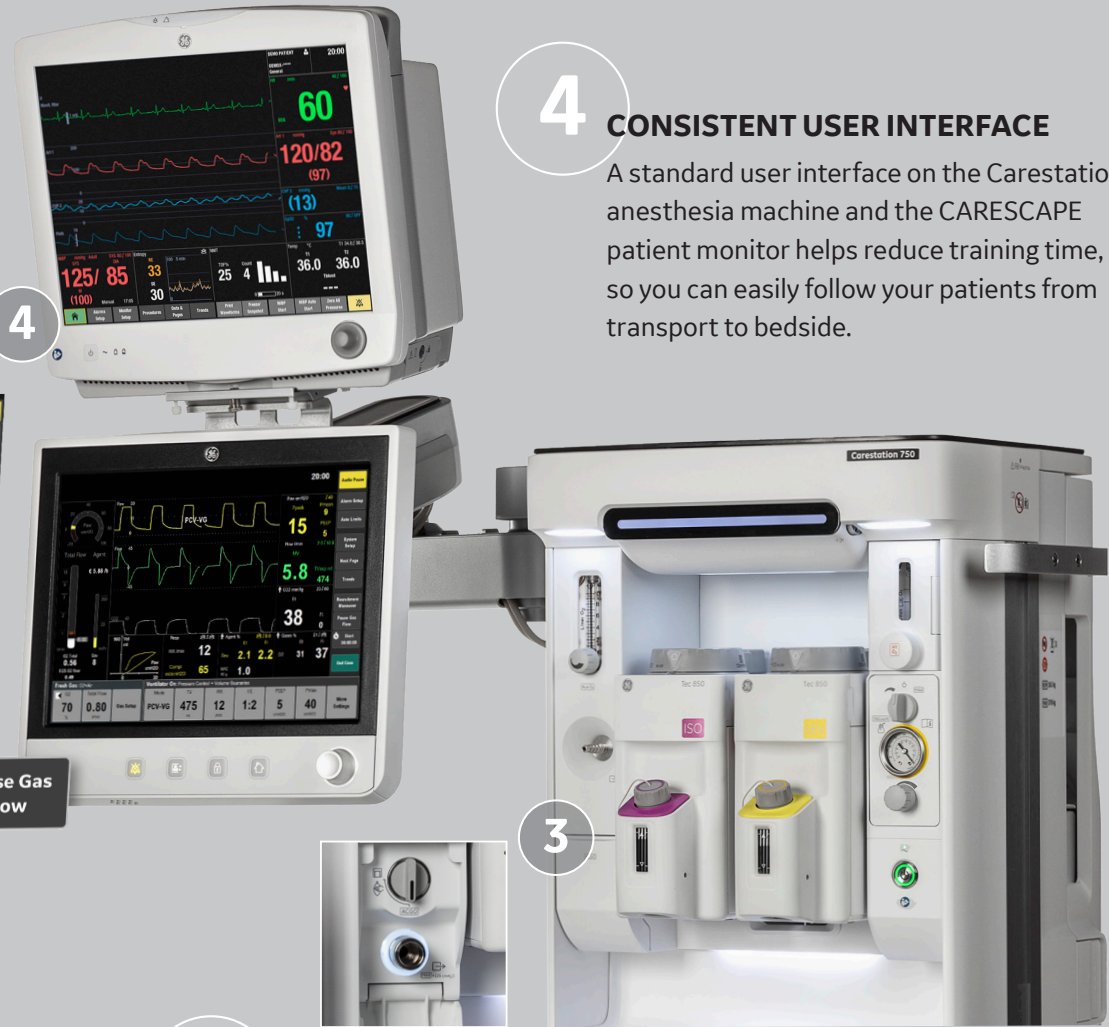

C EFFICIENT, ERGONOMIC DESIGN

Complete cases with speed, efficiency and comfort

Based on extensive usability studies, we designed the Carestation 750 machine to be compact with features that provide convenience and comfort to help alleviate workday stress.

Ergonomic convenience

An optional, full-function premium arm supports the display. With extend, tilt, raise/lower, and 360-degree swivel, you have maximum flexibility to stay close to the patient and have all controls within easy reach. The display can be positioned for optimal viewing even if you need to step or move into an alternative position without compromising your view.

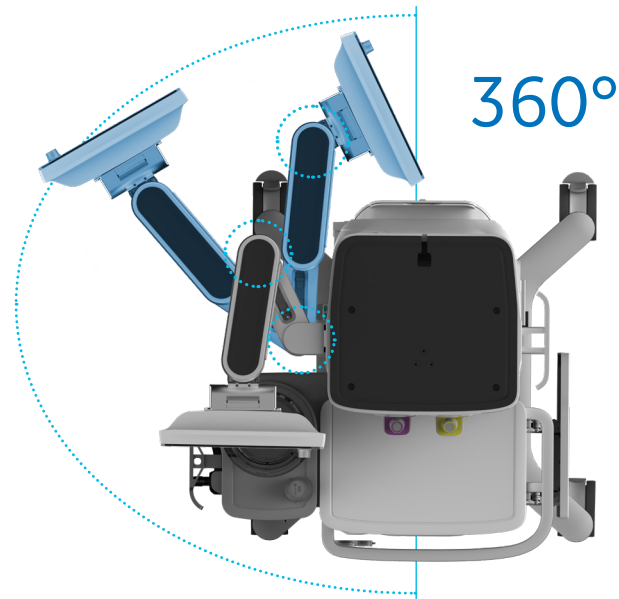

YOUR CHALLENGE

35%

of patient injuries from anesthesia gas delivery are preventable by proper pre-use machine check⁶

OUR SOLUTION

Fast, Complete and Self-guided Checkout

The daily checkout process is as simple as it is thorough. Clear, step-by-step, guidance on the screen lets you run a complete checkout, including a vaporizer test, in as little as three minutes.

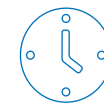

3 minutes

Streamline your care pathway

The efficient, electronic design of the CARESCAPE ONE monitor connects therapy and recovery to help improve user workflow. In a simulated user study the monitor reduced total transport time by 26% and transport user errors by 60% compared to an analogous solution.

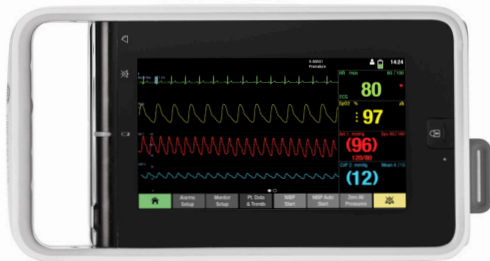

26%
reduction in
transport time
(based on simulated
usability study)⁸

60%
reduction in
user errors⁸

Simplified cable management

A specially designed rear door covers all cables and hoses, yet still allows easy access to gas cylinders, gas connectors and circuit breakers. Cables and hoses are shielded from dust, and the smooth exterior simplifies surface cleaning.

A hose hook makes it easy to maneuver the unit inside and outside the OR. The machine top provides ample workspace with lighting for dark environments.

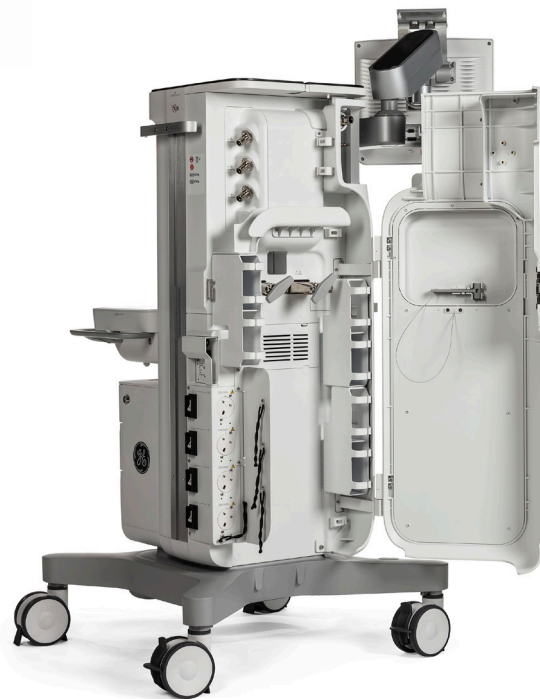

Enjoy new capabilities on a familiar, proven platform

The Carestation 750 machine is built on an established GE anesthesia platform trusted by clinicians worldwide.

YOUR CHALLENGE

OR delays may cost a hospital over

\$60
per minute⁷

OUR SOLUTION

Modular Design

Self-contained subsystems such as the integrated gas module (A) and breathing system (B), are designed for rapid removal and replacement without tools to minimize OR late starts or downtime.

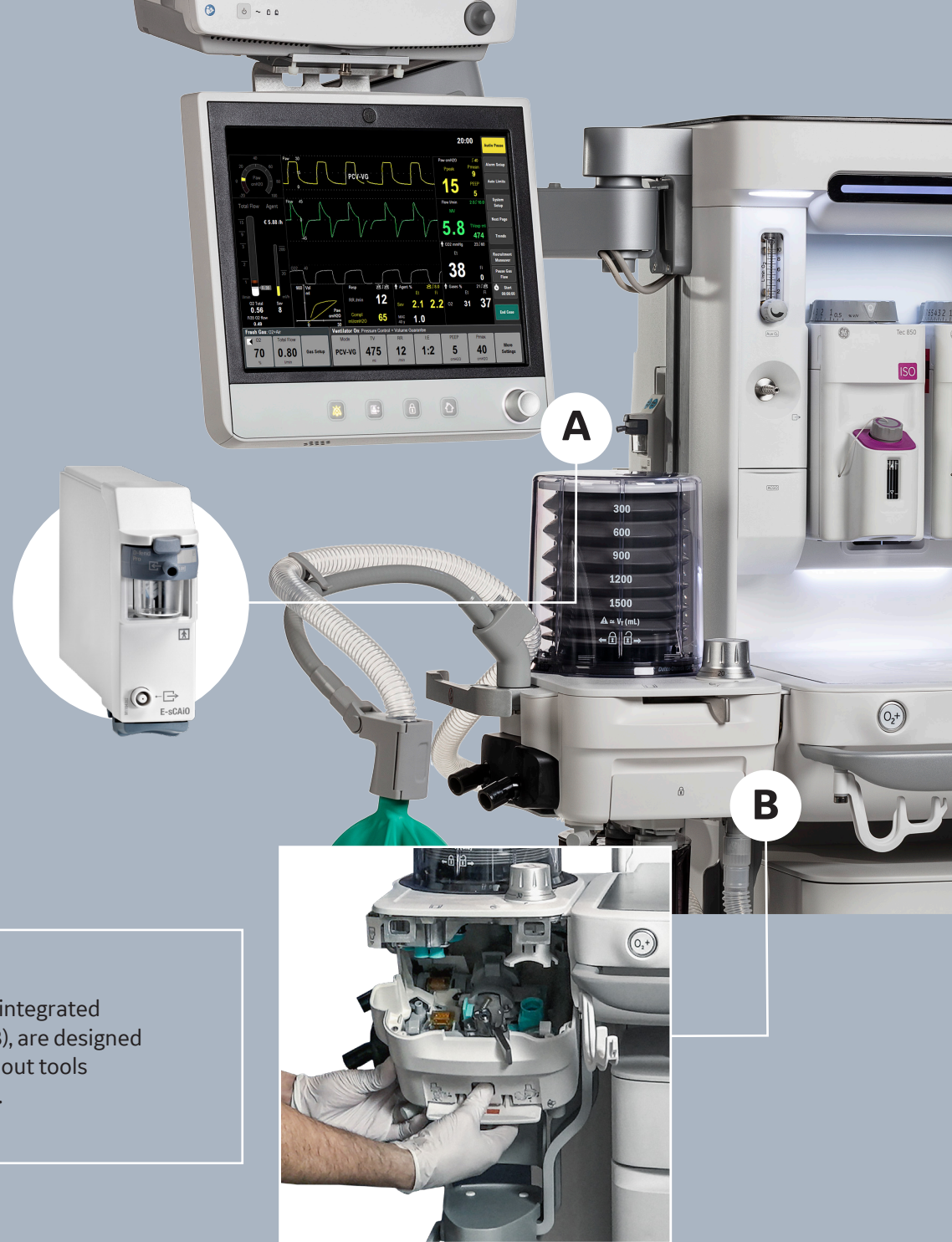

Tool kits and solutions allow you to manage diverse patients and procedures with precision, enabling positive patient outcomes.



Pause gas flow

Simplify temporary circuit disconnect.



Spirometry loops and waveforms

Visualize ventilation status for easy interpretation.



ecoFLOW

Practice low flow with confidence.



Single-step and multiple-step lung recruitment

Automated lung recruitment maneuvers.

Electronic flow valve technology provides fast response times, quickly achieves set pressures and precisely delivers tidal volumes as low as 5 ml in pressure controlled ventilation (PCV) mode¹⁰. This precision helps deliver personalized care to ventilate from the simplest to the most complex cases and patient types.

Thanks to its small volume and linear design, The Compact Breathing System provides fast response to changes in fresh gas flow composition even at low and minimal flow. Maintenance is simplified with the modular and quick release design.

These features are available across the platform to deliver a consistent experience for your staff, simplify your adoption of new technology, and protect legacy investments in your anesthesia equipment fleet.



Tailored service to fit your needs and budget

The Carestation 750 machine is designed for ease of service to help minimize downtime and total cost of ownership.

We've simplified planned maintenance and made more than two dozen serviceability improvements, all to reduce service costs significantly. Parts are available quickly and conveniently through our subscription-based online Service Shop.

GE experts stand ready to support you with flexible service offerings, from support for your in-house biomedical team to comprehensive service agreements delivered by GE engineers. We'll help you choose a plan that complements your staff's expertise with our engineers, so you can schedule, reliable care throughout the life of your machine.



Supplies and Accessories

Every moment in the OR is critical for the patient and clinician. Quality and uptime cannot be compromised, and that is why GE Healthcare offers you a reliable, one-stop solution for compatible supplies and accessories. With an expansive portfolio verified by our engineers, you can rest easy knowing you are using high-quality components that optimize machine performance. This includes a simple, single point of contact for all questions, accessories and service needs with your GE Healthcare equipment.





Education to complement your workflow

GE Healthcare helps you tailor education on your anesthesia delivery systems, so you acquire knowledge the way you want it, when you need it.

Access online training courses for your Carestation 750 system and learn how to maintain the equipment and use advanced features. On-demand videos deliver clinical insights on topics such as ecoFlow and dilution effect, lung recruitment and spirometry, checkout and calibration, and assembly and disassembly of the breathing system.

GE Healthcare can help maximize your investment and reach your goals through clinical training and education.





gehealthcare.com

This product depicted in this brochure is not available in countries without regulatory approvals. This product is not cleared by the US FDA. Not for sale in the United States.

Full product technical specifications are available upon request. Contact a GE Healthcare Representative for more information. Please visit www.gehealthcare.com

Data subject to change. © 2020 General Electric Company – All rights reserved.

GE, the GE Monogram, Carestation and CARESCAPE are trademarks of General Electric Company.

Nothing in this material should be used to diagnose or treat any disease or condition. Readers must consult a healthcare professional.

1) Hospitals can be spending an extra 15–30% for anesthetic agents in an OR due to high flow estimates derived from the GE Healthcare ecoFLOW Calculator. <https://gehealthcareamer.my.salesforce.com/sfc/#version?selectedDocumentId=069a0000004eOn7>

2) Global Warming Potential of Inhaled Anesthetics: Application to Clinical Use, Susan M. Ryan, MD, PhD, and Claus J. Nielsen, CSc International Society for Anaesthetic Pharmacology www.anesthesia-analgesia.org July 2010; v111 #1.

3) Environmental Protection Agency. Emissions facts: greenhouse gas emissions from a typical passenger vehicle. Available at: <http://www.epa.gov/oms/climate/420f05004.htm#key>

4) Improper ventilation during Anesthesia can cost over \$25K/case (3) in post-op lung complications. Fleisher, L. A., & Linde-Zwirble, W. T. (2014). Incidence, outcome, and attributable resource use associated with pulmonary and cardiac complications after major small and large bowel procedures. *Perioperative Medicine*, 3(7). doi:10.1186/2047-0525-3-7.

5) Murphy GS, Brull SJ. Residual neuromuscular block: Lessons unlearned. Part 1: Definitions, incidence, adverse psychological effects of residual neuromuscular block. *Anesth Analg* 2010; 111:120-128.

6) Patient injuries from anesthesia gas delivery equipment. Mehta SP, Eisenkraft JB, Posner KL, Domino KB. *Anesthesiology* 2013; 119: 788-95.

7) The ergonomic inconvenience can cost ORs over \$60 per minute due to delays. Source: Optimizing your Operating Room: OR, Why Large, Traditional Hospitals Don't Work. *International Journal of Surgery*. Giroto, Koltz, Drugas. 2007.

8) Revolutionizing Patient Transport Monitoring, GE Healthcare usability study JB58083XX. The comparative usability study was conducted in a simulation center whereby intubated OR patients were transported to the ICU by transport nurses.

9) SPI portion of Adequacy of Anesthesia concept is not available for sale in USA and has not been cleared or approved by FDA.

10) GE benchmark studies from 2011: GE Healthcare PCV to Tidal Volume Data Collection Test Results. Actual results may vary and are dependent on the patient. DOC0933949/DOC0970424